

Standard Full Nut

Thread Type: UNC / BSW - Coarse

Thread Direction: Right Hand

Material: Stainless Steel

Class Grade: A2-70 G304

Corrosion Protection Level: Excellent

Standard: ANSI B18.6.3

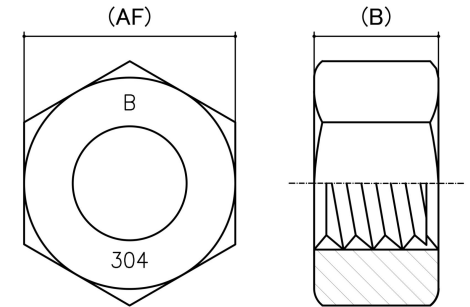

*CAD drawings shown for graphic representation only.**

| Size | Thread Pitch (TPI) | Thread Type | Overall Nut Height (B) (mm) | | Across Flats (AF) (mm) | | Spanner Size (AF) (inches) | sku (qfind) |
|-------|--------------------|-------------|-----------------------------|-------|------------------------|-------|----------------------------|-------------|
| | | | Min | Max | Min | Max | | |
| 1/4" | 20 | Coarse | 5.39 | 5.75 | 10.88 | 11.16 | 7/16 | 41SC14 |
| 5/16" | 18 | Coarse | 6.56 | 6.94 | 12.43 | 12.76 | 1/2 | 41SC516 |
| 3/8" | 16 | Coarse | 8.13 | 8.56 | 14.00 | 14.28 | 9/16 | 41SC38 |
| 7/16" | 14 | Coarse | 9.28 | 9.78 | 17.15 | 17.48 | 11/16 | 41SC716 |
| 1/2" | 13 | Coarse | 10.85 | 11.38 | 18.70 | 19.05 | 3/4 | 41SC12 |
| 9/16" | 12 | Coarse | 12.02 | 12.60 | 21.87 | 22.23 | 7/8 | 41SC916 |
| 5/8" | 11 | Coarse | 13.59 | 14.20 | 23.42 | 23.83 | 15/16 | 41SC58 |
| 3/4" | 10 | Coarse | 15.68 | 16.90 | 27.64 | 28.58 | 1-1/8 | 41SC34 |
| 7/8" | 9 | Coarse | 18.39 | 19.72 | 32.24 | 33.33 | 1-5/16 | 41SC78 |
| 1" | 8 | Coarse | 21.11 | 22.53 | 36.83 | 38.16 | 1-1/2 | 41SC1 |

Disclaimer:

Dimensional data and technical information was obtained from publically available sources and not acquired through standard agencies. It has been completed and compiled for reference purposes only; where discrepancies are found they are subject to change without notice. Bolt & Nut Australia makes no warranties or representations regarding the accuracy and validity of the compiled information and data. Contact the relevant standard authorities for accurate and detailed information.

* CAD drawings may not reflect diameter, thread length or overall length.

© Bolt & Nut Australia Pty Ltd. All rights reserved.

Version: 18 Mar 2024